

# ATRAS

## 4th Generation

Registration, sorting and centrifugation

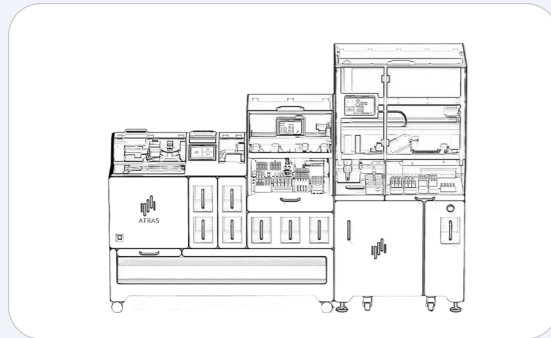



## 2025

### 4th Generation +

- Introduction of CSpin
- Features like centrifugation status check
- More flexibility of extension options



## 2021

### 4th Generation

- Increase of throughput by approx. 40%
- Connection to transport systems like InTrac
- Introduction of the Racksorter RS2

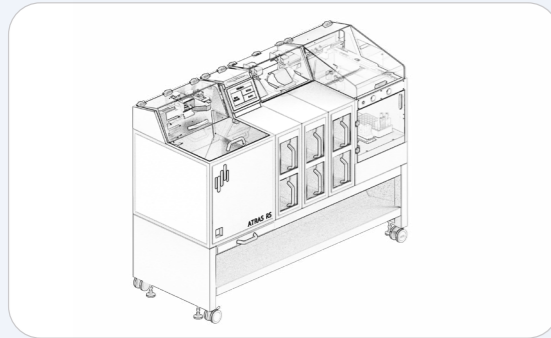

## 2018

### 3rd Generation

- Increase of throughput by approx. 25%
- Basis for various OEM developments
- Numerous new features (e.g. STAT Input)



## 2014

### 2nd Generation

- Further developments based on customer feedback
- Improved reliability and robustness
- Introduction of the first Racksorter



## 2012

### 1st Generation

- First series production of the ATRAS
- A modular system right from the start
- Delivery of the first units

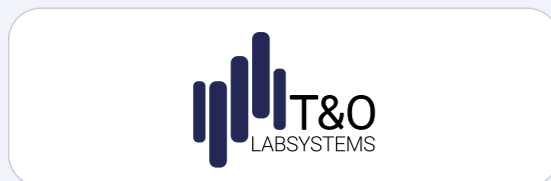

## 2009

- Foundation of the company T&O LabSystems
- Start of the development of the ATRAS series

# CONTENT

## System overview 4

## The modular system 6

Workflows and sample volumes are different in every laboratory. The ATRAS series takes account of these challenges. Due to its numerous configurations and options, the ATRAS series offers customized solutions for your needs.

### The modularity of the ATRAS 8

### Racksorter in detail 10

### Examples of ATRAS modularity 12

### CSpin in detail 14

### Extension options 16

### ATRAS TS - the smallest member of the ATRAS series 17

## It simply runs 18

In the daily laboratory routine, employees are constantly challenged and have to focus on the essentials. We ensure that the registration and sorting of samples runs reliably in the background. Thus, the ATRAS is designed to provide the highest productivity and quality.

## T&O LabSystems 23

# SYSTEM OVERVIEW

## The 4th ATRAS Generation at a glance

The ATRAS series offers cost-efficient bulk loading and sorting into target bins and racks. Thanks to the latest addition, now with automated centrifugation.



Touchdisplay

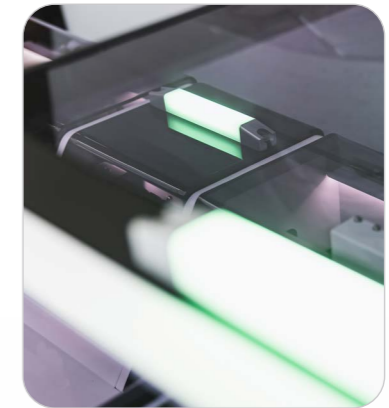

Status indicator lamp



CapIdent



STAT Input



Piston detection



Belt



Centrifugation status



SIQ bin

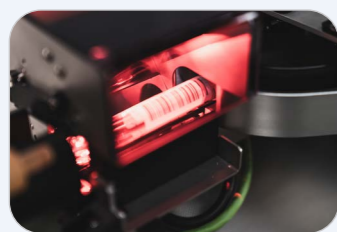

Barcode scanner



Individual rack area with output and input racks



Bulk Input



Bulk Output



Individual rack area with barcode alignment



Centrifuge

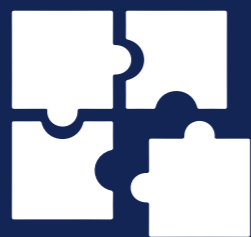

# THE MODULAR SYSTEM

## Flexible solutions for your requirements

Every laboratory has different workflows and sample volumes. The ATRAS meets these challenges with numerous configurations.

## Work process

### Your challenge

Due to different requirements, each laboratory has established and optimized its own processes. The diversity of processes represents a challenge for the automation of preanalytics.

### Our solution

Thanks to the modularity of the ATRAS, numerous processes can be automated – from sample registration, sorting, centrifugation to archiving as bulk. The ATRAS is scalable and can be adapted to new requirements at any time.

## Workload

### Your challenge

Within a short time frame, high sample volumes have to be processed. Samples have to be registered quickly and error-free in order to be transferred to subsequent processes. Manual registration and sorting ties up capacities and can lead to

### Our solution

The ATRAS registers and sorts samples with a throughput of approx. 3,000 samples/hour and reduces registration and sorting errors. Combined with a Racksorter module, the ATRAS offers fast bulk to rack sorting within the smallest space. The CSpin module automates the placement and repositioning of tubes before and after centrifugation. For laboratories with lower sample volumes the ATRAS TS benchtop sorter offers an ideal solution.



# THE MODULAR SYSTEM

## The modularity of the ATRAS

Together, we configure the ATRAS in a way that perfectly suits your requirements. The ATRAS can be expanded at any time.

1

### Configure the ATRAS for your processes and sample volume

Each ATRAS starts with a Base Unit. To this further Bulk Output as well as Racksorter and CSpin modules can be added.



#### The Base

The Base Unit consists of a Bulk Input, a separation module and a Bulk Output module with two target bins. Manually or via an InTrac Inlet, samples can be loaded continuously into the spacious hopper of the ATRAS. They are registered according to the FIFO principle.



#### Bulk Output

After registration, samples are sorted into defined target bins as bulk. Sorting is based on customer-defined rules.



#### Racksorter

On a compact footprint, registered samples are sorted into racks and into bulk target bins. Throughput per module is approx. 1,300 samples/hour.\*



#### CSpin

Automated and continuous centrifugation of 500 samples/hour per module, with integrated rack building after centrifugation.

\*The total system throughput multiplies for the same sorting targets with the addition of racksorter modules (have a look at page 11).

2

### Equip the ATRAS according to your requirements



#### STAT Input

Continuous loading of urgent samples during operation with digital STAT flagging.



#### Piston detection

Recognition of insufficiently drawn aspiration samples to prevent interruptions on subsequent analyzers.



#### CapIdent

Best-in-class cap colour detection due to an in-house developed spectral measurement.

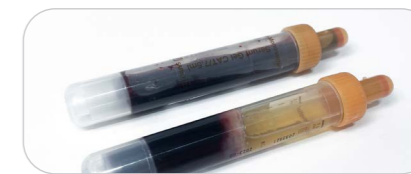

#### Centrifugation status

Identification of the centrifugation status to select the correct subsequent process.



#### Barcode alignment

Automatic alignment of samples for subsequent analyzers.



#### SIQ bin

Sorting out of samples in question for manual check.

3

### Integrate the ATRAS into your processes

A particular high degree of automation in preanalytics can be achieved by connecting ATRAS to sample transportation systems, such as our in-house developed transport system InTrac. This allows a continuous sample flow to the ATRAS as well as to the subsequent station.

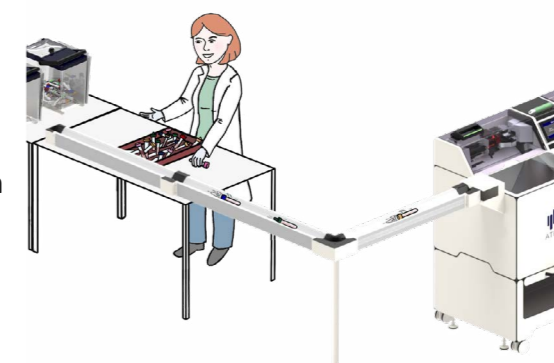



# Have a closer look

1

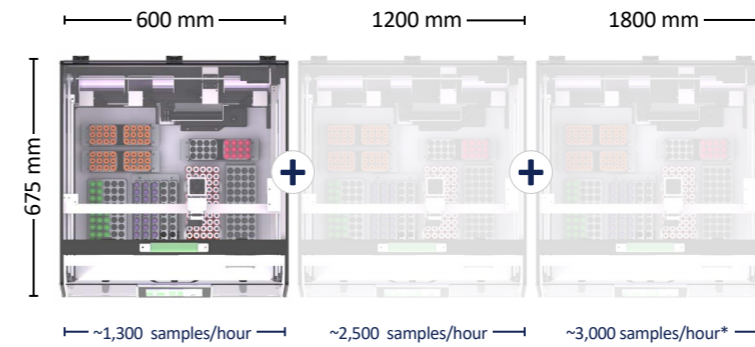

\*The Bulk Input separates approx. 3,000 samples/hour

## High throughput on a minimum footprint

On an area as small as a standard-sized washing machine, sorting is combined into racks, centrifuge buckets and target bins. Adding another module doubles the usable rack area. Depending on the sample mix, this can lead to almost a doubling of throughput when using identical targets. In total, up to three Racksorter modules can be combined in one ATRAS system. This allows a throughput of approx. 3,000 samples/hour on an area of just 1.5 m<sup>2</sup>.

2



## Easy access

Highly frequented racks are easily accessible without barriers. By pulling out the rack sorting area, even rear racks are quickly at hand.

4

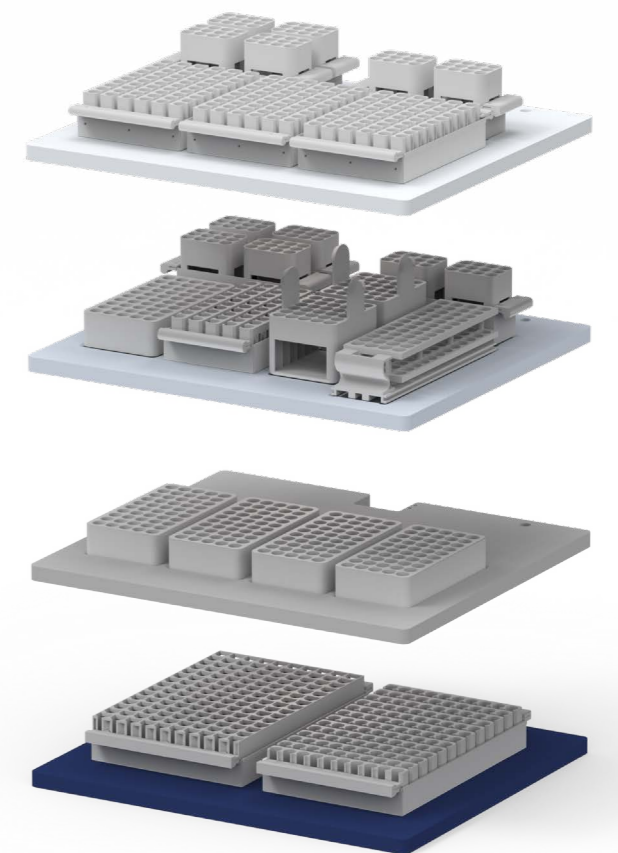

Endless layout possibilities

3



## Independent module

Each Racksorter module can be operated independently via the intuitive display. The status indicator lamp shows the status of the respective module. In case of a necessary intervention in the module, the overall ATRAS system continues to run.

## Individual rack area

The rack area is freely configurable within the scope of its specifications. Customer-specific requirements can be realized.

# THE MODULAR SYSTEM

## Racksorter in detail

Using a minimal amount of space, the module combines the sorting of samples into target bins, racks and centrifuge buckets.

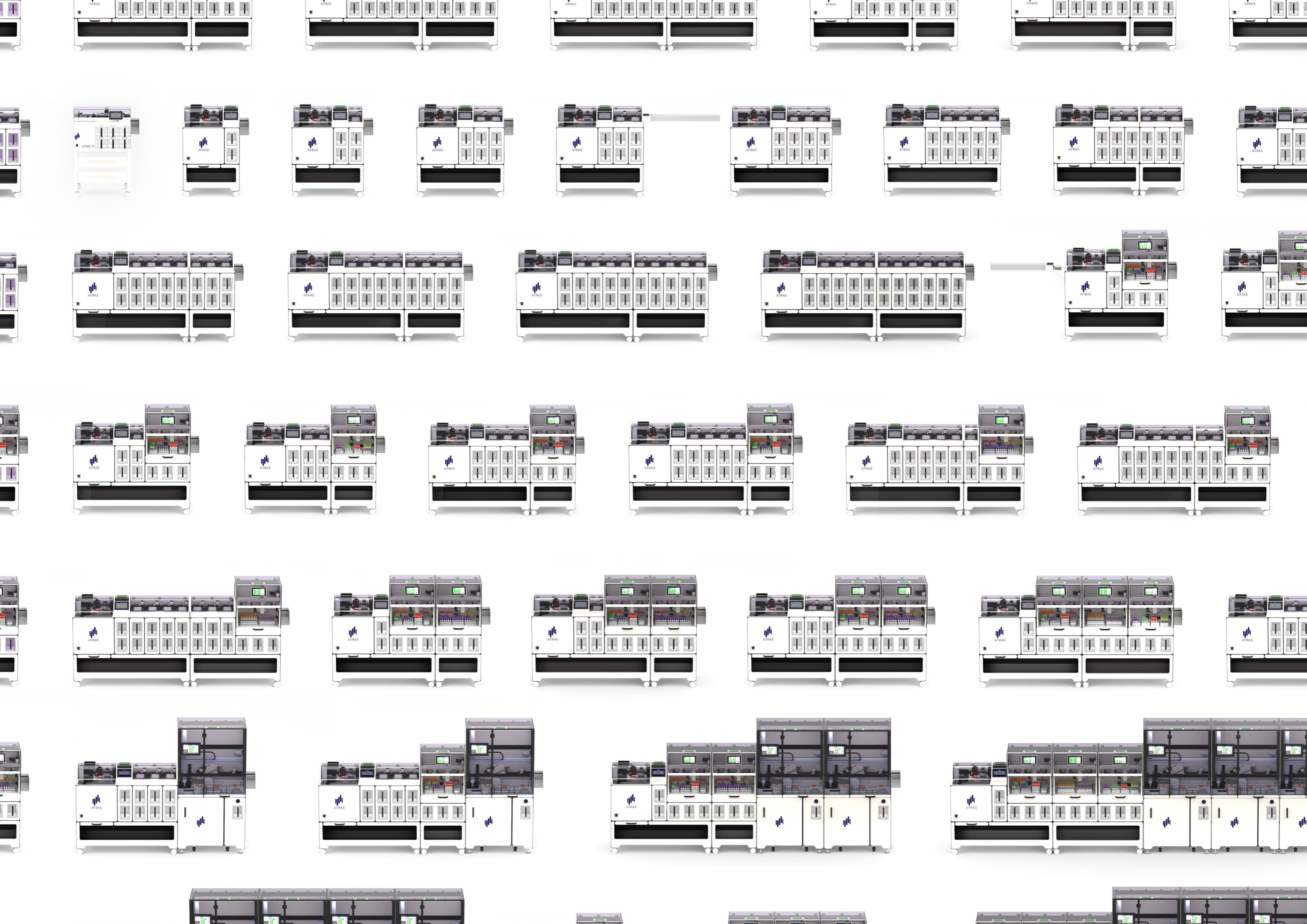



# THE MODULAR SYSTEM

## CSpin in detail

CSpin allows continuous centrifugation and automated distribution of sample tubes. This increases the degree of automation and enables efficient use of manual resources.

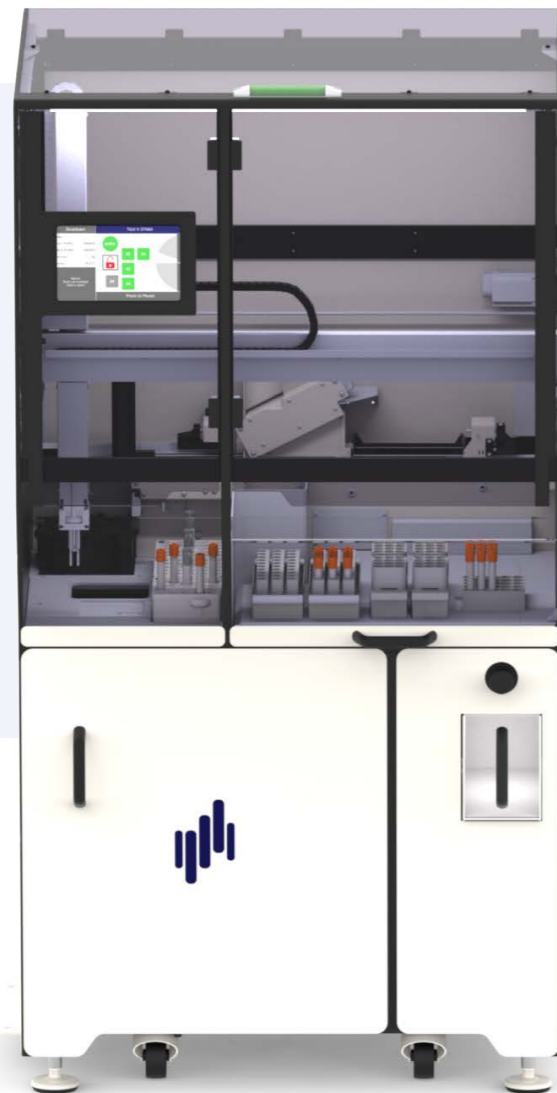

## Have a closer look

1

### Always in balance

Samples are automatically weighed and placed into centrifuge buckets according to their weight.

### Flexible application

Tubes from the belt can be centrifuged and are either put into an output rack or are returned to the belt. Samples can also be directly sorted into an output rack without centrifugation. Input via rack is possible as well.

### Continuous centrifugation

As soon as a centrifugation cycle is completed, the next cycle starts automatically – even if the following buckets are not completely filled.

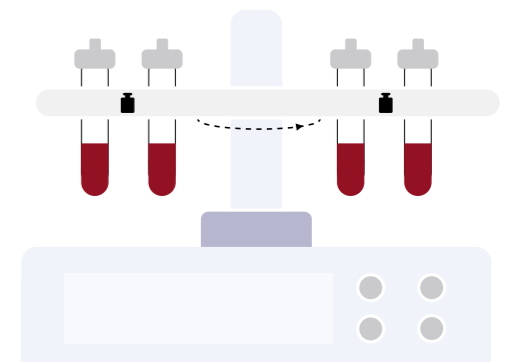

2



### Always accessible

Individual rack areas with up to eight in- and output racks are directly and easily accessible. By sliding out the rack area, even rear samples are easy to reach.

3

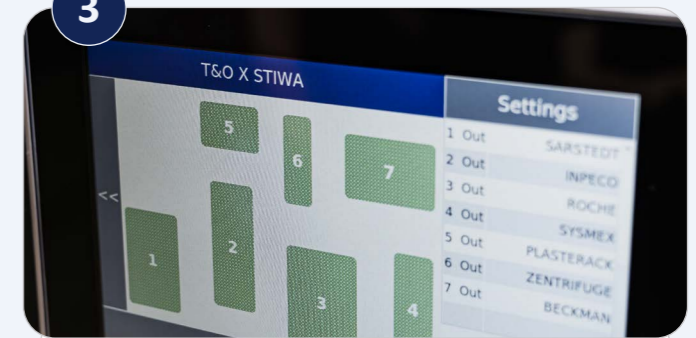

### Intuitive display

Each centrifuge can be configured with custom profiles via the display: Centrifugation duration and G-force can be selected, racks can be labeled individually, and the centrifugation progress can be monitored.

4

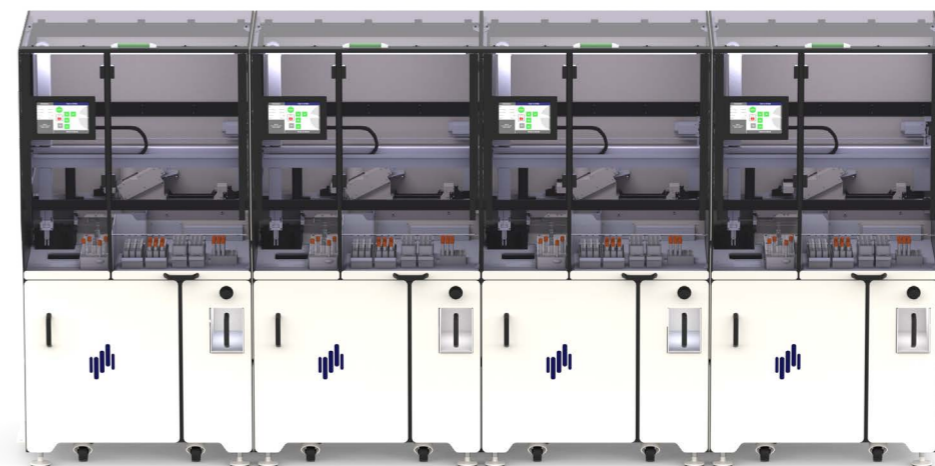

### Flexible, automated centrifugation

CSpin can centrifuge 500 samples/hour at an 8-minute centrifugation time. Up to 96 samples can be processed per cycle.

Connecting up to four CSpin modules enables increased total throughput or parallel centrifugation with different profiles – depending on lab-specific challenges.



# THE MODULAR SYSTEM

## Extension options

### Capacities & configurations

ATRAS is a flexible system. The Base Unit consists of the Bulk Input, a Bulk Output module and the SIQ bin. Further configuration of the ATRAS system follows a modular design. It allows the integration of up to 11 Bulk Output modules with a total of 22 target bins, 3 Racksorters each with 3 target bins and 1 individual rack area, and up to 4 CSpin modules, each featuring one target bin and an individual rack area.

A combination of the different modules is not only possible, but commonly used in practice. Feel free to contact us to bring your desired configuration to life.

**Bulk Output module with 2 target bins**



**Racksorter module with 3 target bins 1 individual rack area**



**CSpin module with 1 target bin 1 individual rack area**



# THE MODULAR SYSTEM

## ATRAS TS – the smallest member of the ATRAS series

The ATRAS TS combines functionality and performance in a compact design. It is a cost-efficient solution for laboratories with limited space. With a throughput of approx. 1,300 samples/hour, the ATRAS TS ensures fast sample processing.

### Examples

**A** 10 target bins + 2 rack areas + SIQ bin

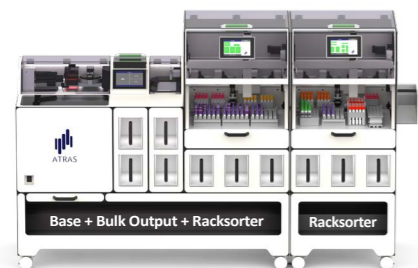

**B** 8 target bins + 2 rack areas + SIQ



**C** 13 target bins + 1 rack area + SIQ

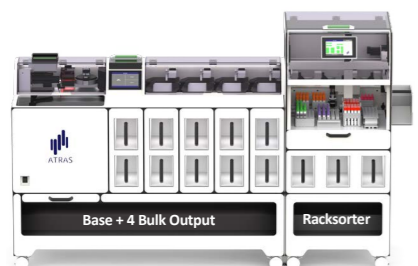

**D** 7 target bins + 3 rack areas + SIQ

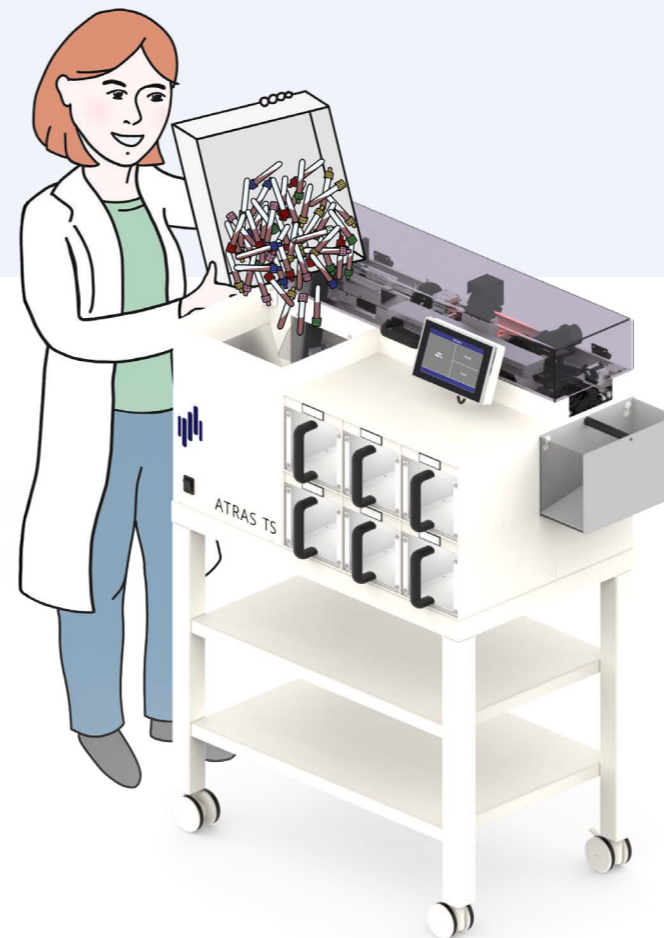

- Compact design, low space requirement
- Simple and intuitive operation
- Throughput of approx. 1,300 samples/hour
- All common sample tubes
- Cap colour detection
- Connection to your laboratory software
- 6 target bins + SIQ bin for samples in question



# IT SIMPLY RUNS

## Highest productivity and continuity

Years of experience, a constant exchange with customers and solid engineering are the foundation of the 4th ATRAS Generation. The best sorter is the one you don't notice. It runs reliably and efficiently in the background. The operation is intuitive and simple. Just let the ATRAS run - your employees can concentrate on other tasks.

## You can count on the ATRAS

### Your challenge

In the daily laboratory routine, everything must run reliably and continuously. To ensure a smooth transition to subsequent processes, samples must be registered and sorted quickly, effectively as well as error-free.

### Our solution

With the ATRAS, we focus on the essentials - reliability and performance. The ATRAS is already available in its 4th Generation. Thanks to continuous improvements and customer feedback, the ATRAS series offers highest performance and productivity. The ATRAS simply runs and provides a reliable basis for seamless follow-up processes.

## The ATRAS is simple and intuitive

### Your challenge

Employees constantly operate different devices with different user interfaces. To ensure processes run smoothly, even under time pressure, intuitive operation is necessary. Disturbances that require intervention in the device must be identified and fixed quickly and easily.

### Our solution

The ATRAS is a transparent system with intuitive operation. Samples are visible at all times and can be easily removed after processing. Essential information is immediately and easily accessible. Necessary interventions are indicated via status indicator lamps and signal tones. Troubleshooting assistance is provided directly on the display. The induction training is quick and straightforward.

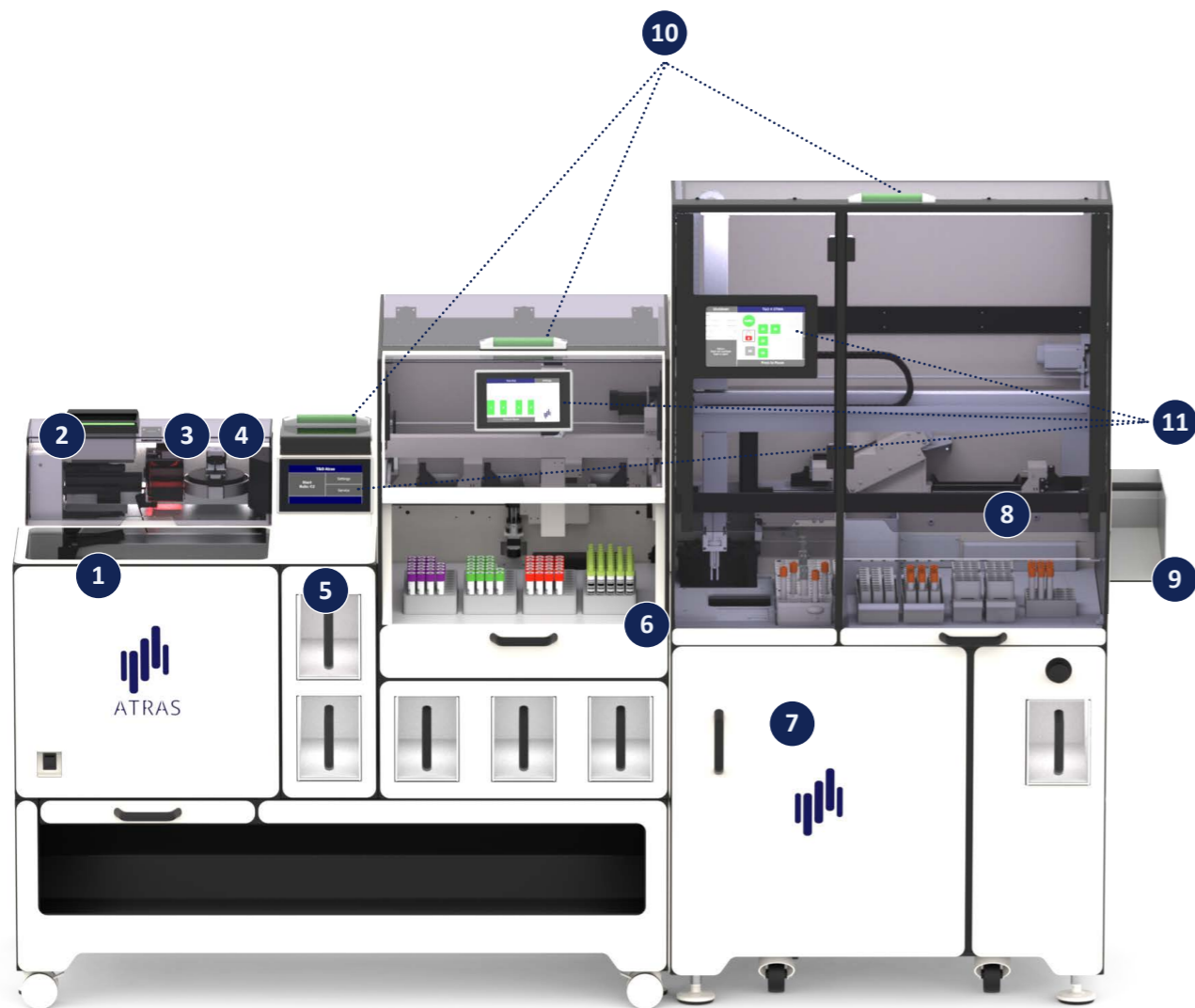

# IT SIMPLY RUNS

## Follow the sample

The samples in the ATRAS are visible at all times. Explore the details that lead to the high productivity and continuity of the 4th ATRAS Generation.



### Simply fill the ATRAS

Samples can be easily loaded into the ATRAS.

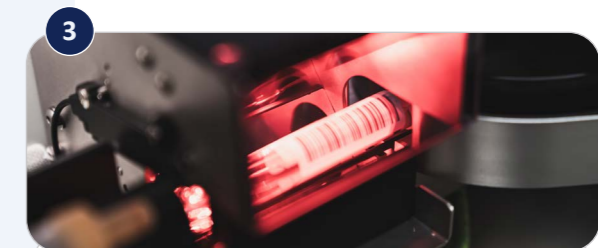

### Fast and reliable registration

Samples are registered on the fly by a highly efficient barcode scanner.



### Continuously load the ATRAS

The generous hopper is designed in consideration of the FIFO principle.



### Best-in-class sample detection

Thanks to an in-house developed spectral measurement, the cap colour is precisely identified. In addition, the diameter and length of a sample tube are measured.



### Use the STAT input for urgent samples

Urgent samples are prioritized in the registration and sorting process by bypassing the hopper. A digital STAT flag is sent to the LIS.

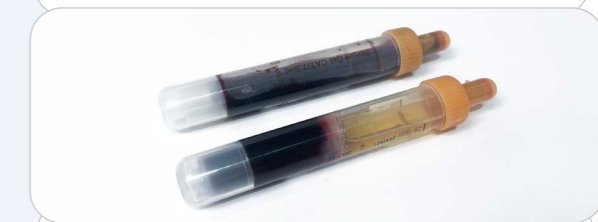

### Centrifugation check

Using light transmission measurement, ATRAS determines whether a gel tube has been centrifuged — without compromising performance — and then selects the appropriate next step.



### Load STAT samples without any compromise in throughput

The sample flow is not interrupted and the throughput remains at a high level.



### Piston detection

Samples you define as inadequate are automatically sorted out before they reach the analytical line to ensure smooth lab operations.



5

**A target bin that fits your preference**

Up to 200 samples fit into the lightweight and robust target bin. Integrated light barriers prevent overfilling. Even when a bin is removed, the ATRAS keeps on running.



6

**All racks within reach**

Highly frequented racks are accessible barrier-free. Rear racks can also be accessed quickly thanks to the pull-out rack area.



7

**High throughput centrifugation**

Continuous centrifugation and automated loading and unloading of samples relieve bottlenecks in your lab.



8

**Automated sample distribution**

After centrifugation, samples are automatically sorted into lab-specific output racks or sent back to the belt.

**Simple and intuitive**

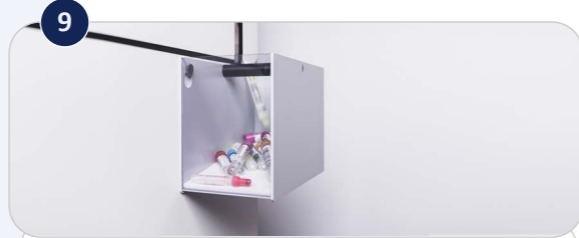

9

**Simple check of SIQ samples**

SIQ samples are sorted out for manual check directly.



10

**Detect the status immediately**

A status indicator lamp and signal tones intuitively indicate whether bins are full or an intervention is necessary.



11

**Operate the ATRAS intuitively**

All essential information of the last 500,000 samples can be quickly accessed via the touchscreen. Users can easily teach the machine new cap colours.



**Control the rack area easily**

Each Racksorter and CSpin is equipped with an intuitive touch screen. Status and configuration can be captured instantly. Necessary interventions are displayed right away while the overall system continues to run.



Dave Lorenzen

Dennis Lorenzen

**T&O LABSYSTEMS**   
 A family business in the 2nd Generation

Trust and fairness are the core foundations of our business relations.

**“A great family business to work with!”**  
 Annica Titzmann, Head of Sample Reception  
 (MVZ Labor Cottbus, Germany)

# What our customers say about the ATRAS series

**"Thanks to InTrac and ATRAS we gained more than 30 minutes in the sample reception area."**

Norbert Brink, Laboratory Operations Manager  
(MVZ Labor Muenster, Germany)



**"The two ATRAS systems have made a small revolution in our sample reception area and have taken us to a new level of sample sorting."**

Annica Titzmann, Head of Sample Reception  
(MVZ Labor Cottbus, Germany)



**"ATRAS relieves our employees and speeds up the processes in the sample reception area."**

Maria Suchanova, Regional manager  
(Medirex Group, Bratislava)



**"A great family-owned company that's a pleasure to work with."**

Annica Titzmann, Head of Sample Reception  
(MVZ Labor Cottbus, Germany)



**"It's a real pleasure to work with ATRAS."**

Nina Clarén, Biomedical Lab Scientist  
(Clinical Microbiology Herlev, Denmark)



**"ATRAS significantly reduces repetitive manual work in the sample reception area."**

Nina Clarén, Biomedical Lab Scientist  
(Clinical Microbiology Herlev, Denmark)



**"The ATRAS systems have significantly optimized the pre-analytical processes in our laboratories located all over Poland."**

(Diagnostyka Lab Chain Group, Poland)

